



TEDELTA
CAPPING SOLUTIONS

CAPPING SOLUTIONS

Machines for aluminum screw cap

Specialized in complete capping system for the
Bottling and packaging industries



.....

Thinking ahead, moving forward

Our commitment in capping technology, allows us to offer tailor made capping Turrets to filler equipment manufacturers and complete capping systems to the end user. More than 40 years of experience, gives us total control of our design and manufacturing of our equipment; Cappers, turrets and capping heads makes us the one and only Spaniard capper manufacturer.

ALUMINIUM SCREW CAPS

Technological Accuracy

- Short skirt R.O.P.P.
- Long skirt R.O.P.P
- Extra long skirt R.O.P.P, etc...



CAPPING MACHINES

INLINE PICK OFF SYSTEM

Semiautomatic CSA-101



- Quick and easy capping head changes.
- Easy manual bottle height adjustment, permitting cap closures of small or large bottles.
- Independent variable speed motor allowing capping head revolution adjustment for different caps and bottles.
- Low maintenance, minimum grease system and high durability

Automatic: Inline CAL-101-ST



- Equipped with our most sophisticated and versatile Head, TEDELTA CR-504-ST.
- Automatic cap positioning and feeding system adapted to cap specifications.
- Small run production lines reaching capping capacity of 3000 bph.

CAPPING MACHINES

ROTARY PICK OFF SYSTEM

Model: CAR-100-ST



- Machine equipped with capping head, TEDELTA CR-504-ST.
- From 3000 bph up to 60000 bph with maximum efficiency.

Model: Duplex Monoblock



- Two or three capping turrets integrated in one machine.
- Each capping turret allows independent use of different cap dispensing systems such as; Pick and Place and Pick-off, depending on the cap to be applied.

CLOSURE CYCLE

The ROPP capping head has been designed to process a perfect closure between PP caps and the bottle neck

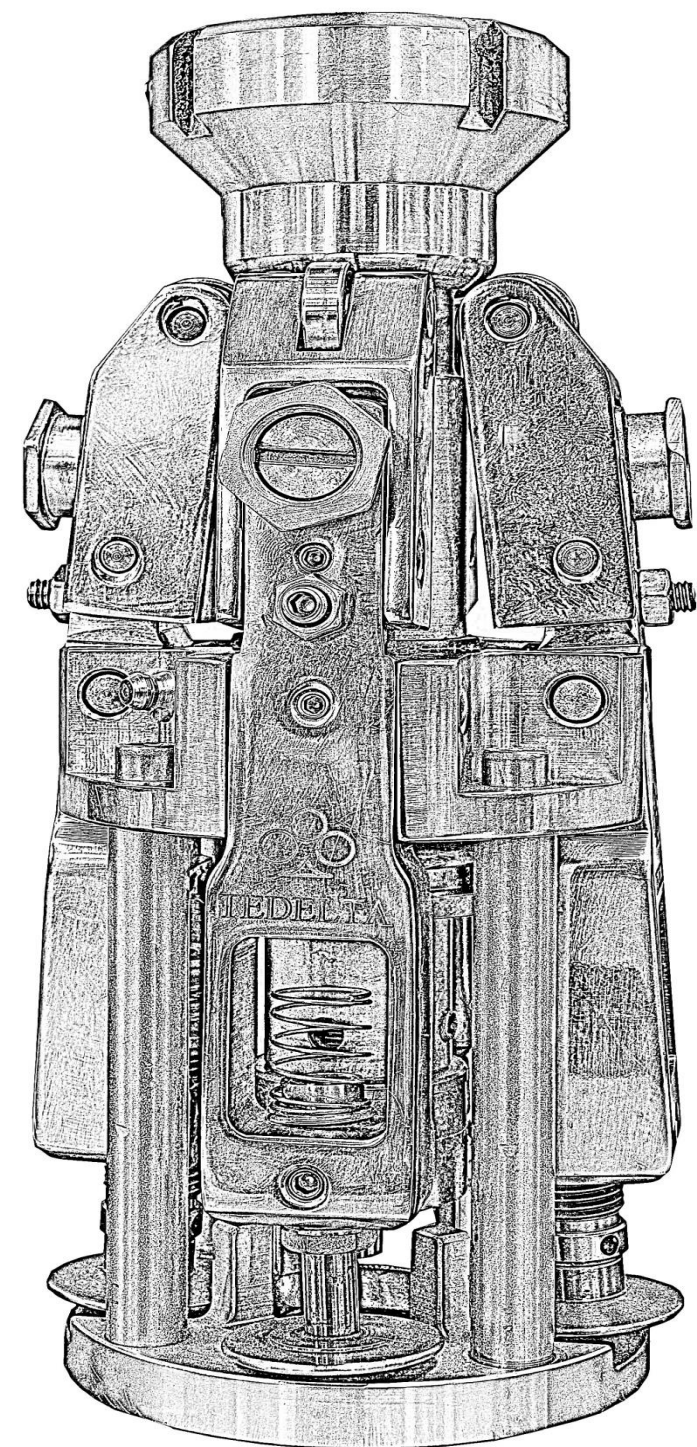

TEDELTACR-504-ST

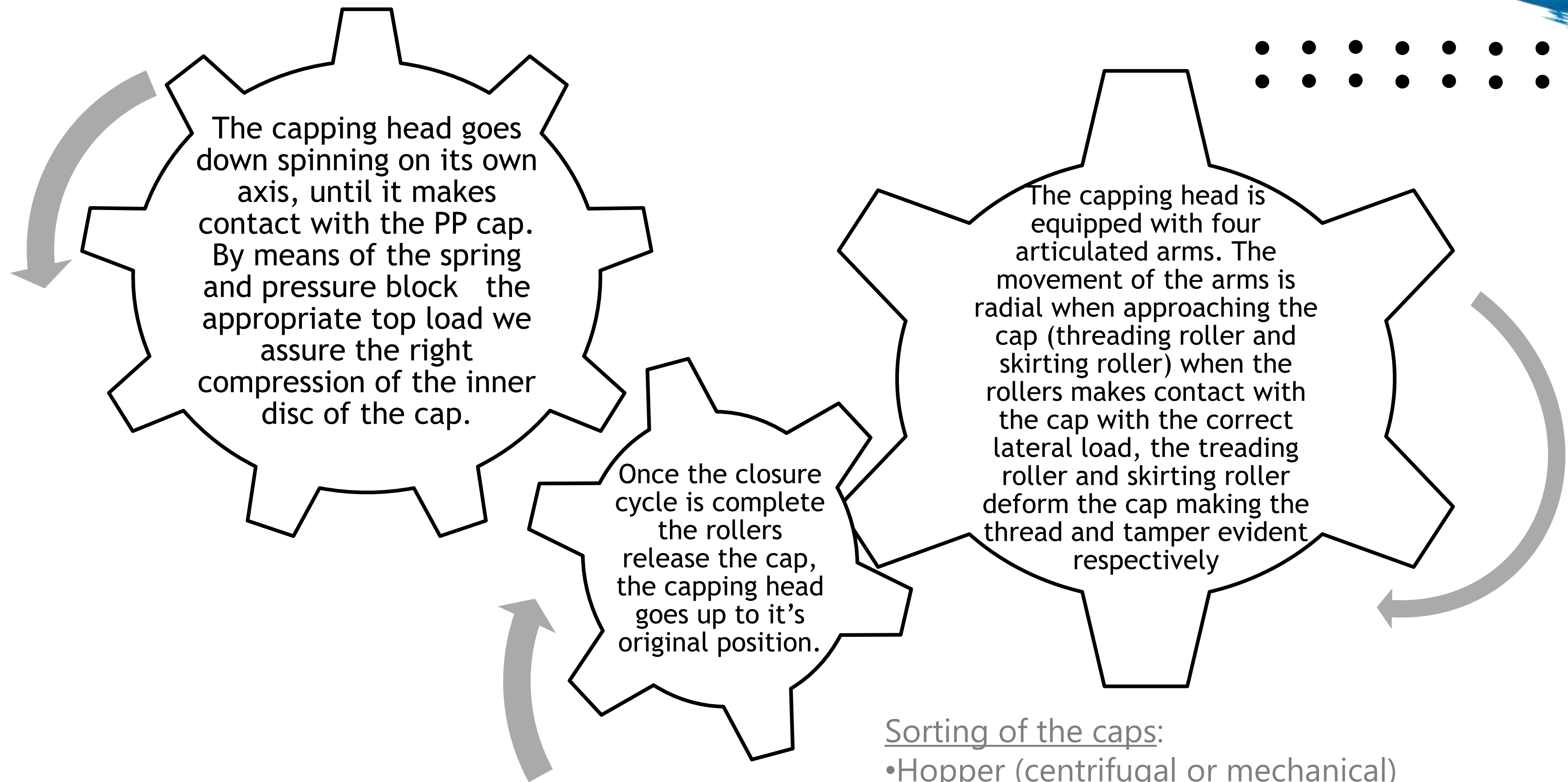

Sorting of the caps:

- Hopper (centrifugal or mechanical)
- Vibration system
- Delivery of the cap: Pick off.

TEDELTA HEAD CR-504-ST

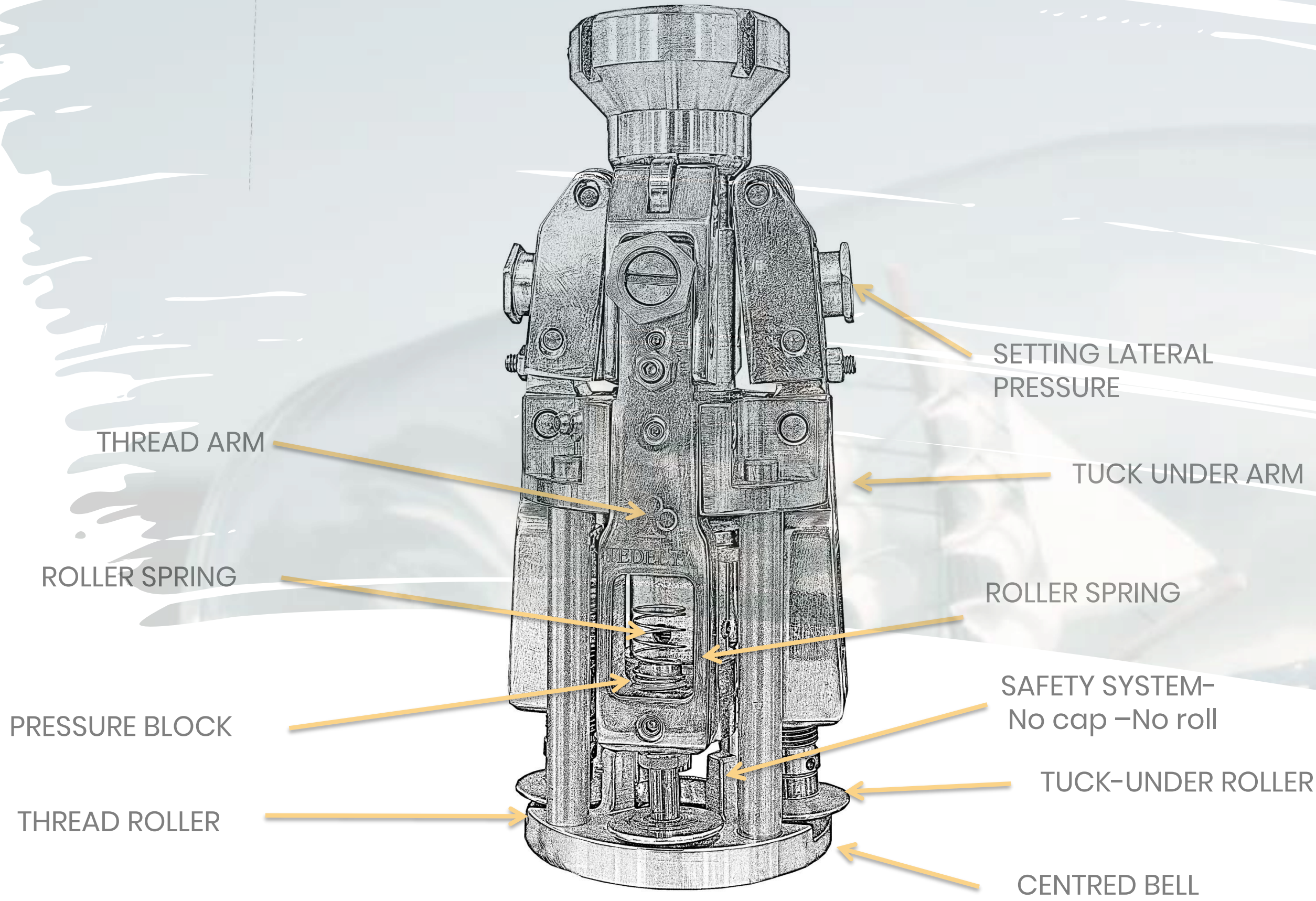
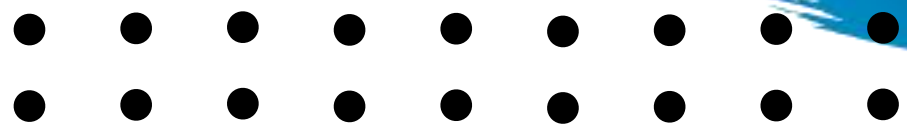

- Manufactured in bronze or stainless steel.
- Designed to perform a perfect and accurate seal of bottles with PP cap.

CAPPING MACHINES

ROTARY PICK OFF SYSTEM

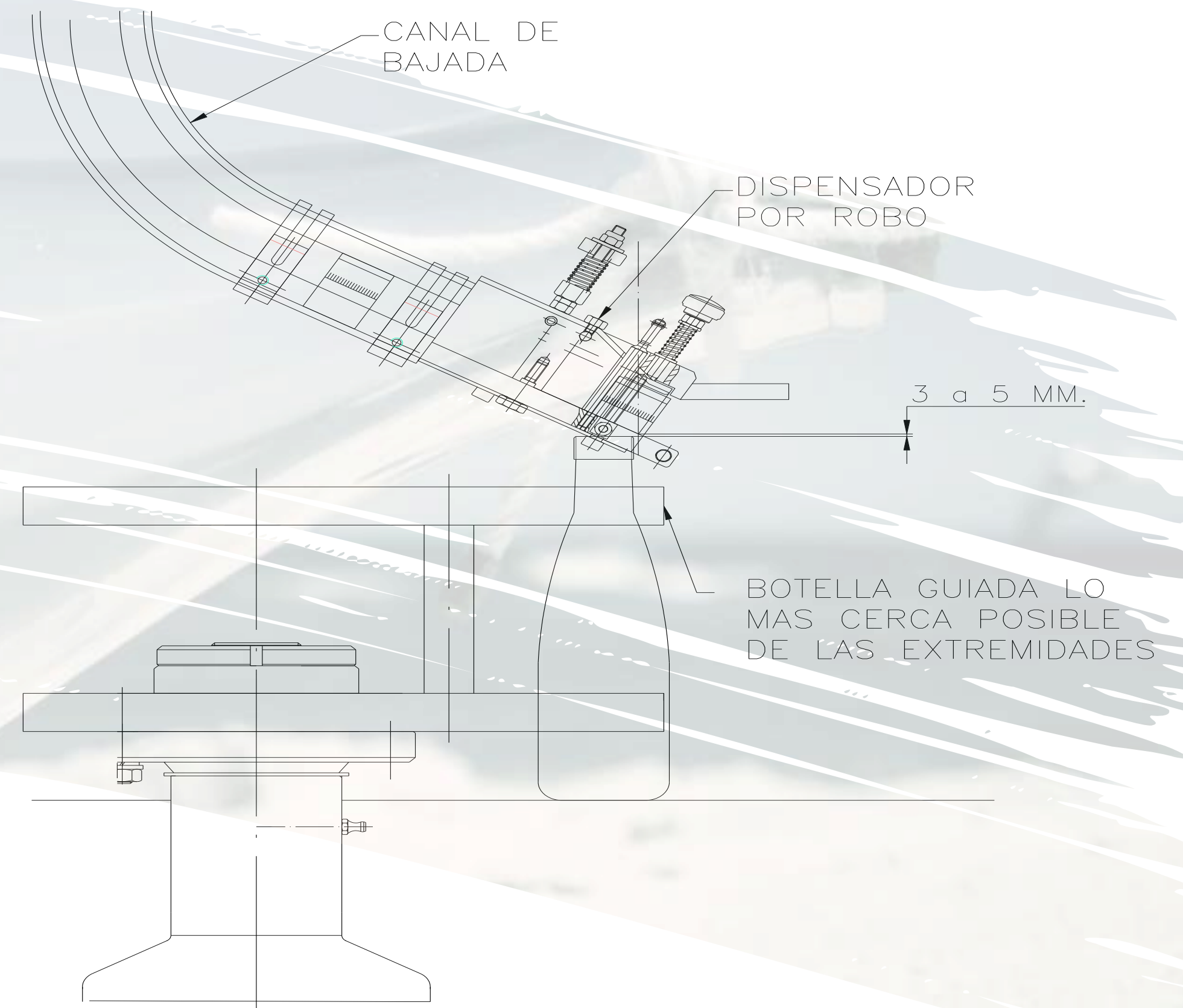
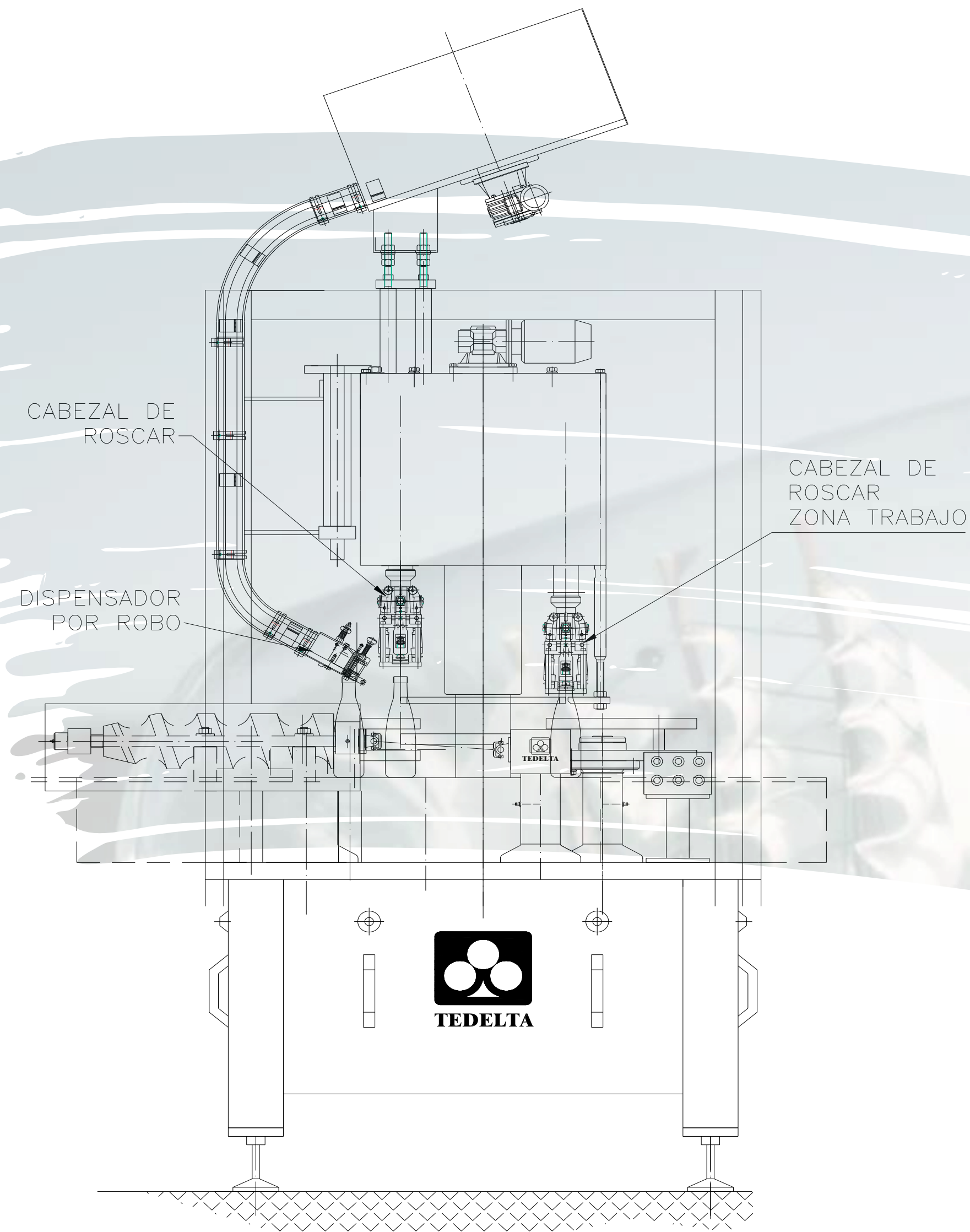

TYPES OF PRESSURE BLOCKS

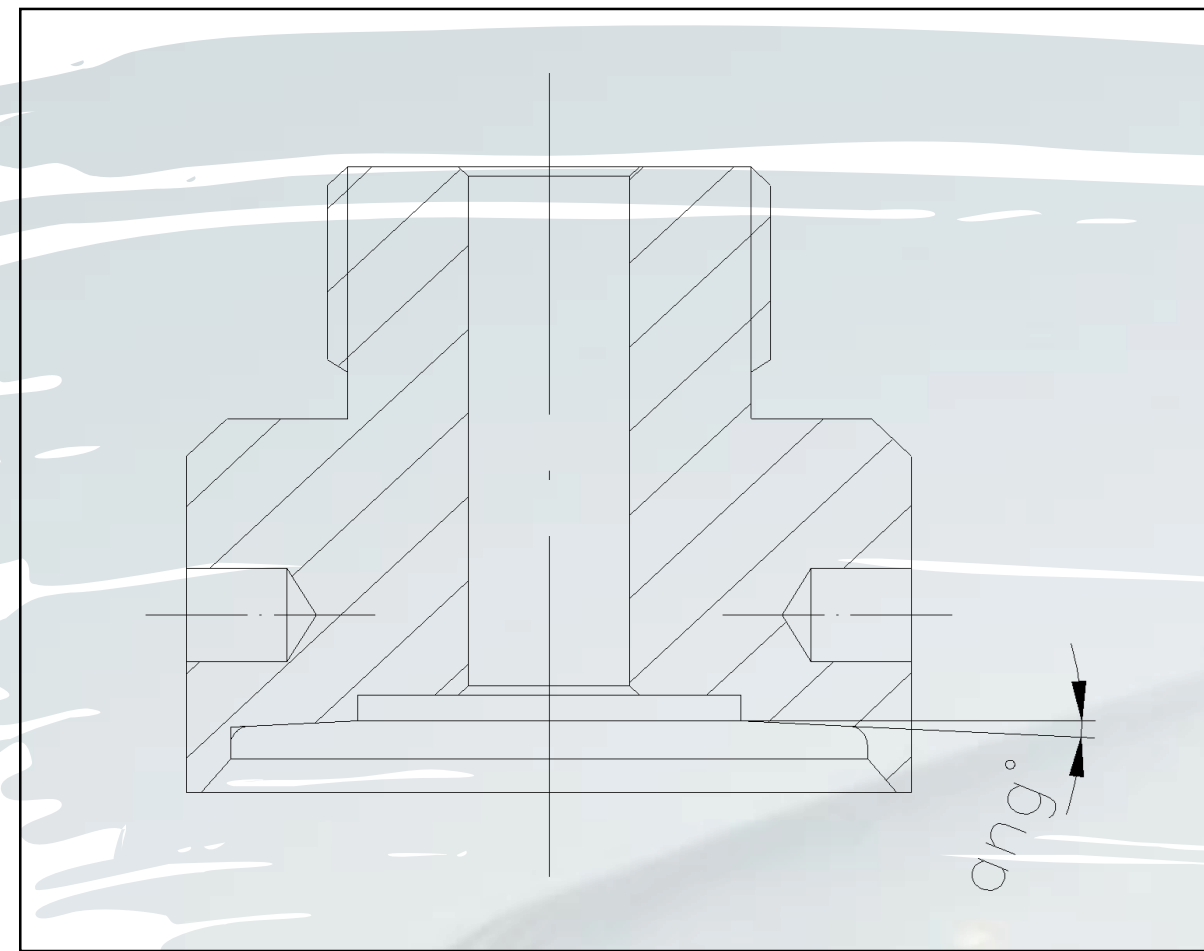

PILFERPROOF STANDARD

- Inclined contact (ang°) between pressure block and SPP-STD capsule producing a perfect closure between disc and rim of the bottle.

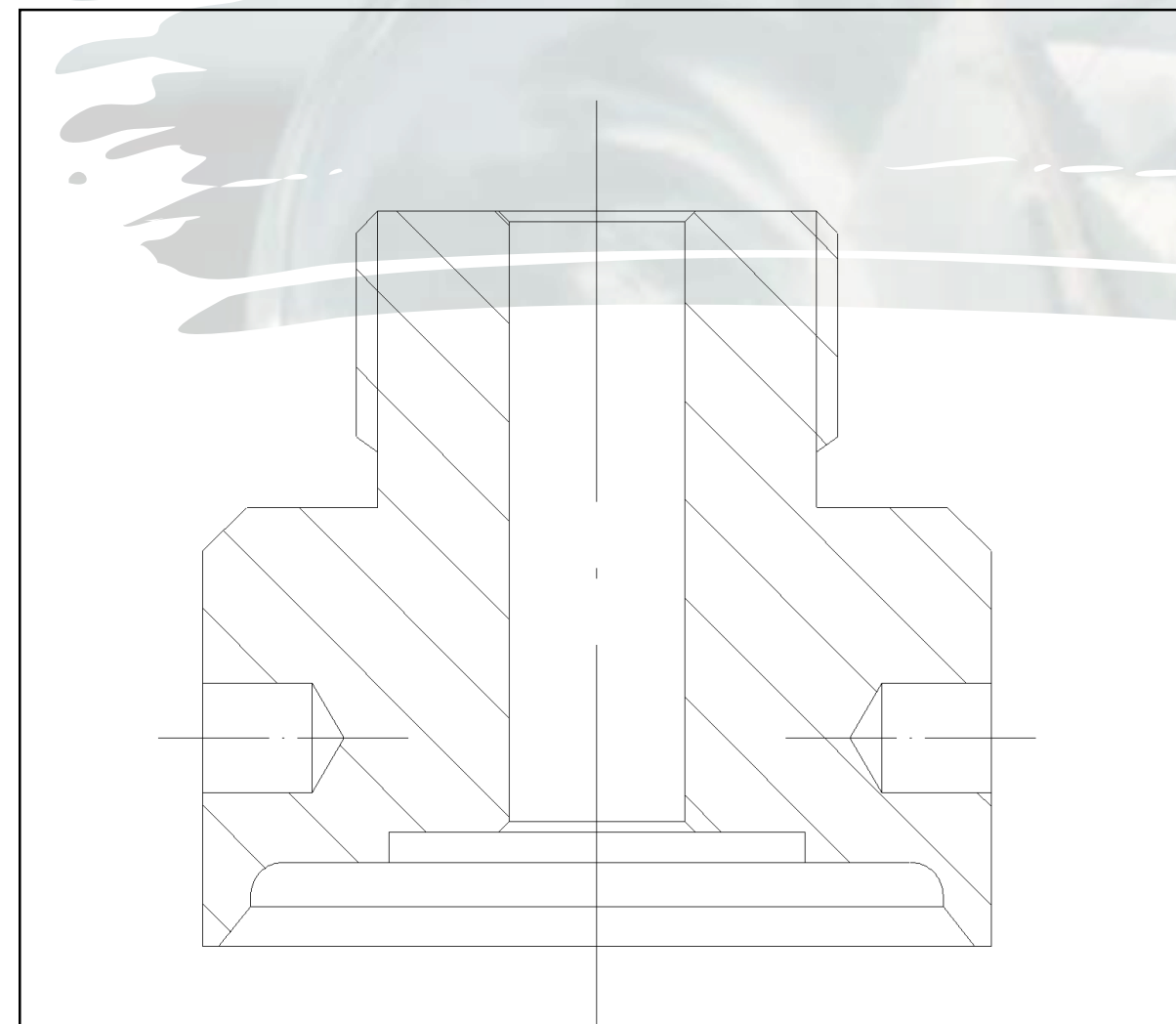

PILFER PROOF- NON REFILLABLE CAP

Fully flat contact between pressure block and cap allowing the entry of the pourer or non-refillable insert in the neck of the bottle

TYPES OF PRESSURE BLOCKS

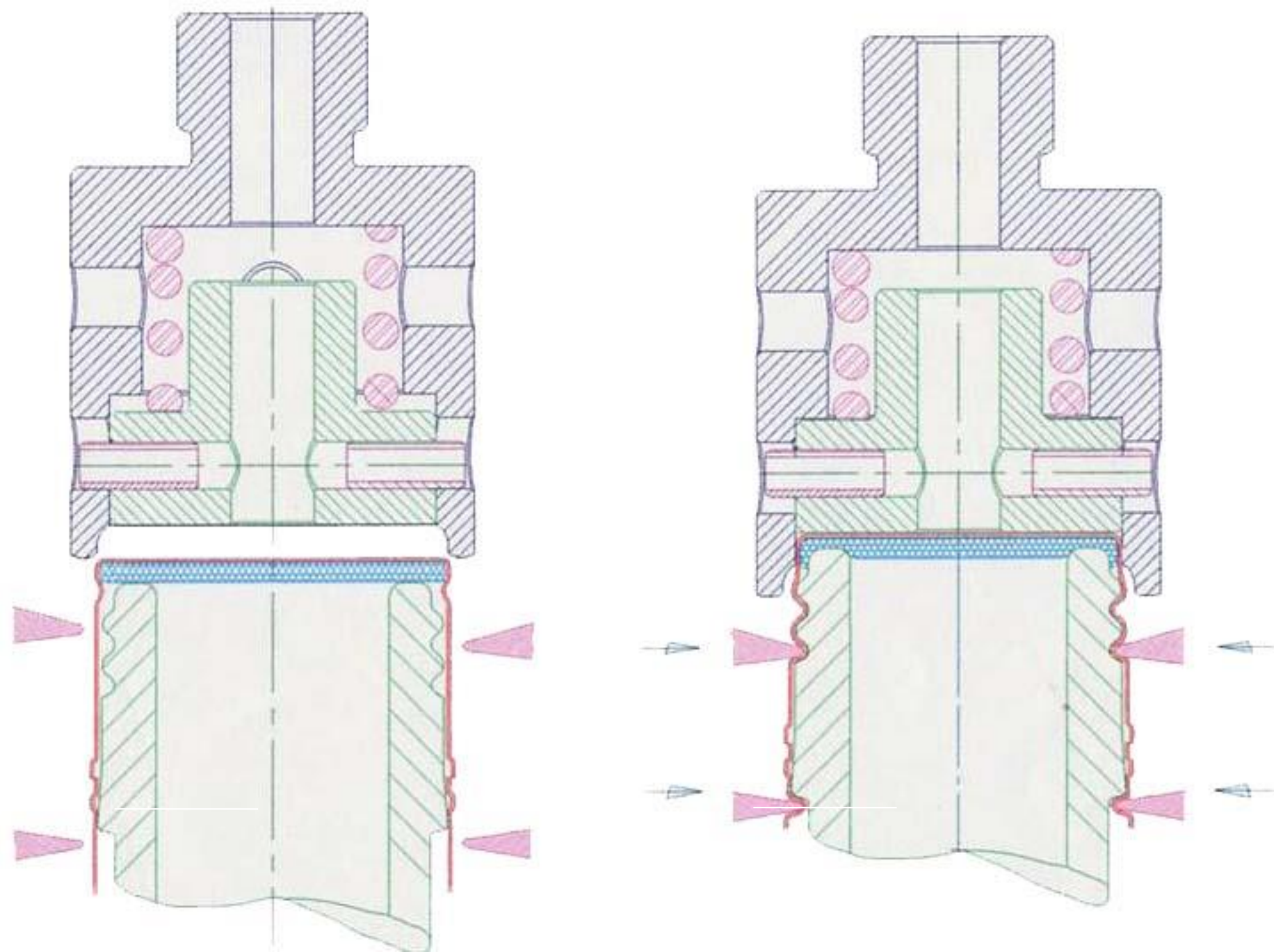

PILFER PROOF

CAP TYPE CAPVIN-STELVIN

Ensures a completely hermetic closure thanks to inner disc deformation made by the pressure blocks.

CONTROL INSTRUMENTS

For quality assurance



TORQUE TESTER

For checking the removal and closing torque of screw or twist caps

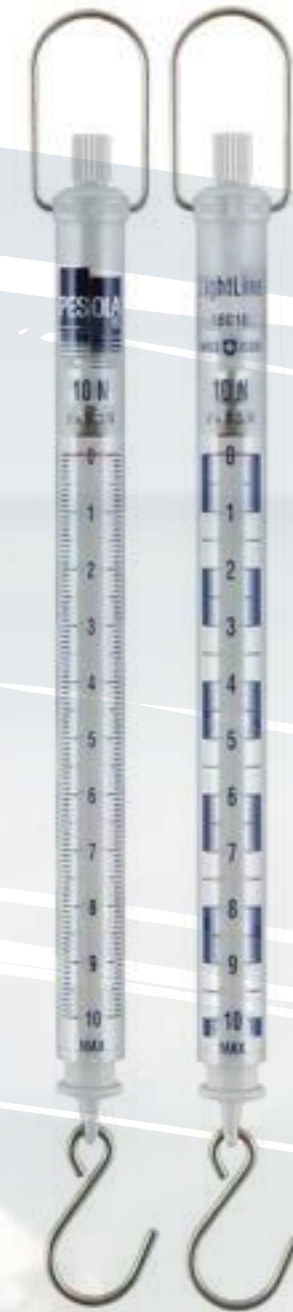

DYNAMOMETER

Control of the lateral or side load of the roller arms.



TOP LOAD TESTER

For checking and setting the top load of the capping head.

TEDELTA INTERNATIONAL

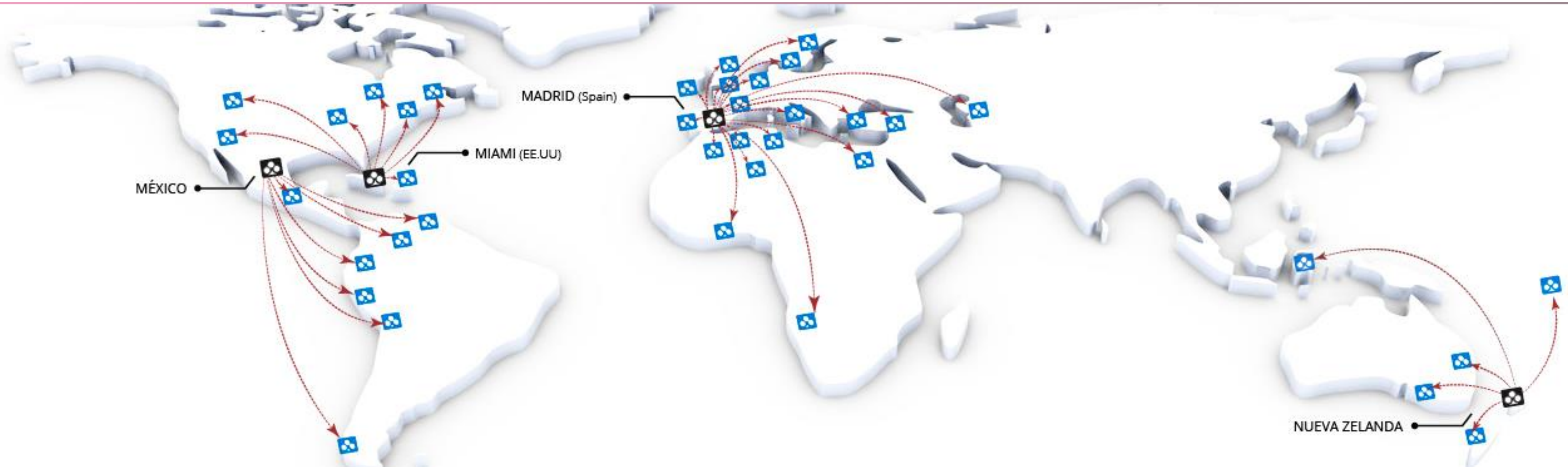

Our commitment to our clients pushes us to higher levels of Service. At Tedelta , we guarantee the fastest and highest quality service assistance, minimizing production downtimes and keeping possible technical problems and maintenance costs at the lowest levels possible.

Visit our machines working

Click Here:



In our you-tube channel you can visualize our machines and know the main technical characteristics of their performance as well as operative videos in operation.

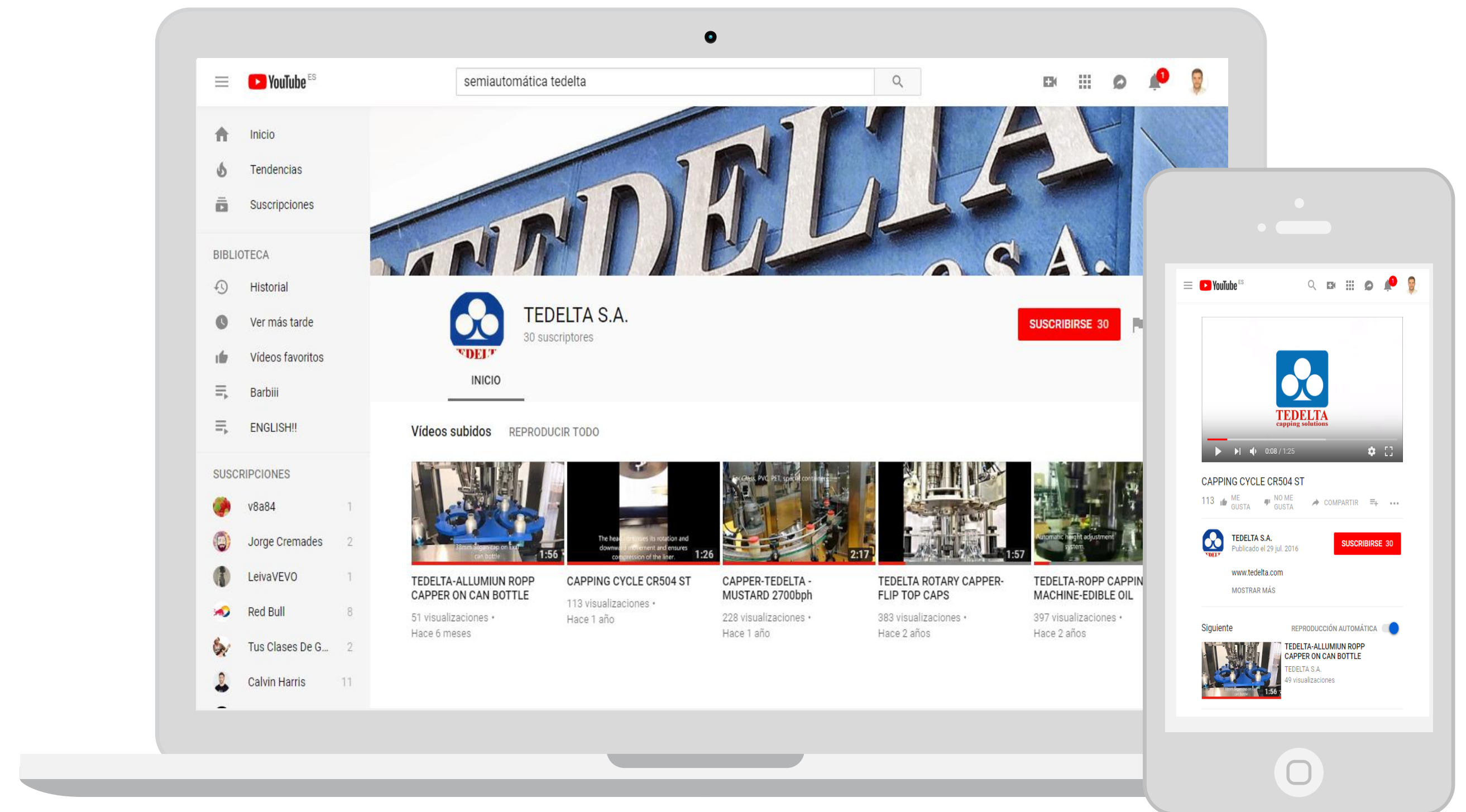

Stay in touch with Us

TEDELTA SPAIN

TLF:+34 91 642 09 43

EMAIL:

COMERCIAL@TEDELTA.ES

ALCOTANES, 29, 28320

PINTO, MADRID

ESPAÑA

TEDELTA NORTH AMÉRICA

EMAIL:

SALES.NORTHAMERICA@TEDELTA.COM

2335 suite R 63 rd Ave.E,

FI ,34203

UNITED STATES

WESTERN REGIONAL OFFICE

TLF: +1 916 626 7688

EMAIL:

TERRY.DYET@TEDELTA.COM

PO BOX 1373

Lincoln, CA 95648

UNITED STATES

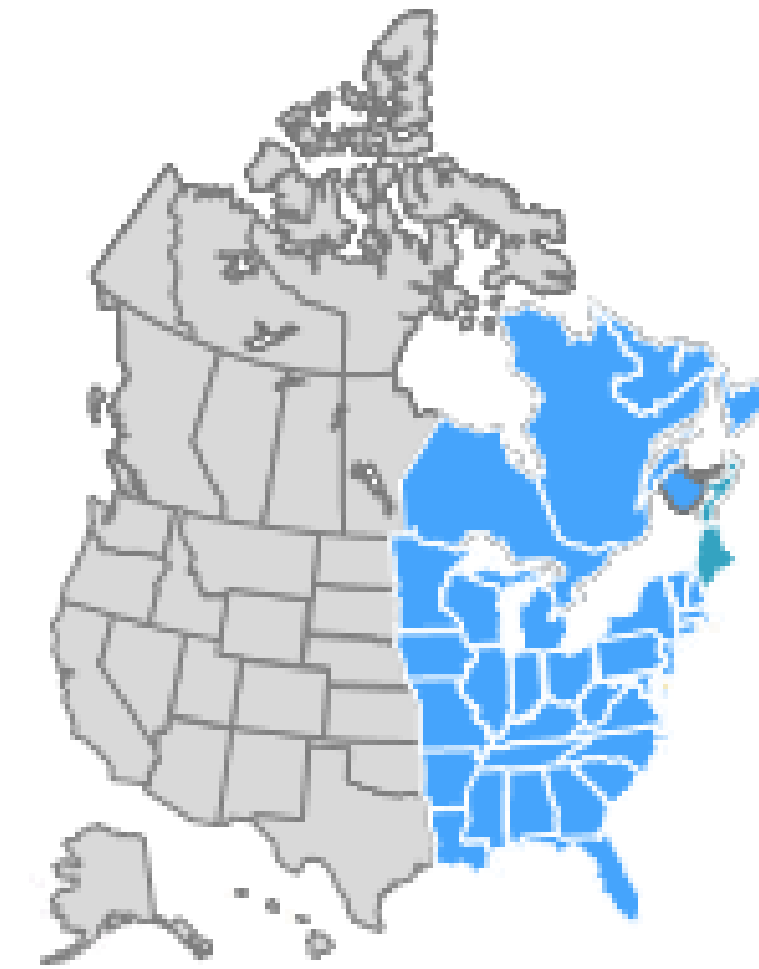

EASTERN REGIONAL OFFICE

TLF: +1 407 399 1986

EMAIL:

ANDY.COWEN@TEDELTA.COM

325 Seminole Woods Blvd.

Geneva. FL. 32732

UNITED STATES

